

Intrinsic Challenges in X-Ray Spectrometry Instrumentation With CdTe Diode Detector

Nascimento, M. R.^{1,2,3}, **Peixoto, J. G.**¹, **Pacífico, L. C.**³, **Macedo, E. M.**^{1,4}

¹ Instituto de Radioproteção e Dosimetria; ² Universidade do Estado do Rio de Janeiro; ³ Departamento de Ciências Radiológicas; ⁴ Laboratório de Produtos para a Saúde do IFBA

E-mail: rebellomatheus99@gmail.com

Resumo: A espectrometria de raios X está sujeita a uma diversidade de problemas que distorcem o feixe medido. Para observar tais questões, foram obtidos espectros nas qualidades N20, N25, N30, N60, N80 e N100 avaliando o impacto de sua não correção nos valores de energia média em comparação com o previsto nos requisitos da norma ISO 4037-1. Os erros percentuais calculados foram de 2%, 2%, 2%, 11%, 9% e 6%, respectivamente, oriundos de deposições parciais de energia, perdas por eficiência e trapping de cargas. Este resultado sugere a necessidade de correção do espectro medido, principalmente para tensões superiores a 30 kV.

Palavras-chave: Espectrometria de Raios X, Espectrômetro de CdTe, ISO 4037-1

Abstract: The X-ray spectrometry is subject to a diversity of problems that distort the measured beam. To observe them, spectra from N20, N25, N30, N60, N80, and N100 radiation qualities were obtained and evaluated their non-correction impact in the values of mean energy when compared with the requirements on ISO 4037-1 standard. The error percentages calculated were 2%, 2%, 2%, 11%, 9%, and 6%, respectively, related to partial energy deposition, efficiency loss and charge trapping. These results suggest the need for correction of measured spectra, mainly for voltages higher than 30 kV.

Keywords: X-ray Spectrometry, CdTe Spectrometer, ISO 4037-1

1. INTRODUCTION

X-ray spectrometry is an experimental tool with large applicabilities. In the metrological field, it is of great importance for characterizing and ensuring the radiation beam quality. However, this well-established technique possesses intrinsic peculiarities to its instrumentation, that depending on its detector material distorts considerably the measured beam (Tomal, et al. 2015). In that sense, this work will focus on the three main issues of its instrumentation that are charge trapping, partial energy deposition in the sensitive volume, and detector efficiency loss.

Aiming to demonstrate the effect of these problems in the measured spectrum it will be made a qualitative analysis of a sealed Am-241 source and quantitative analysis of X-ray spectra in the qualities N20, N25, N30, N60, N80, and N100 described in ISO 4037-1 (ISO 1996). In that way, it will be possible to evaluate the impact of non-corrected spectra in the mean energy values in comparison with the standard.

1.1 What is a Spectrum?

Before going through more specific questions about this type of physical system of interest it is important to define the spectrum. In this context, the answer to it is, in a simple manner, is nothing more than an electric pulses histogram produced in the detector that is organized in small bins of voltage, called by channels. So, after accomplishing a calibration of the scale in channels to values in energy, it will be obtained the “bar code” of the radiation beam making possible to characterize it (Gilmore 2008).

1.2. The Trajectory of the electron: From the Detector to the Histogram

After acquiring a more clear idea of the final result that is obtained with this technique, it is important to understand what happens in the middle of the way of detection to the computer window. In figure 1 it can be seen a simplified scheme of a photon spectrometry system.

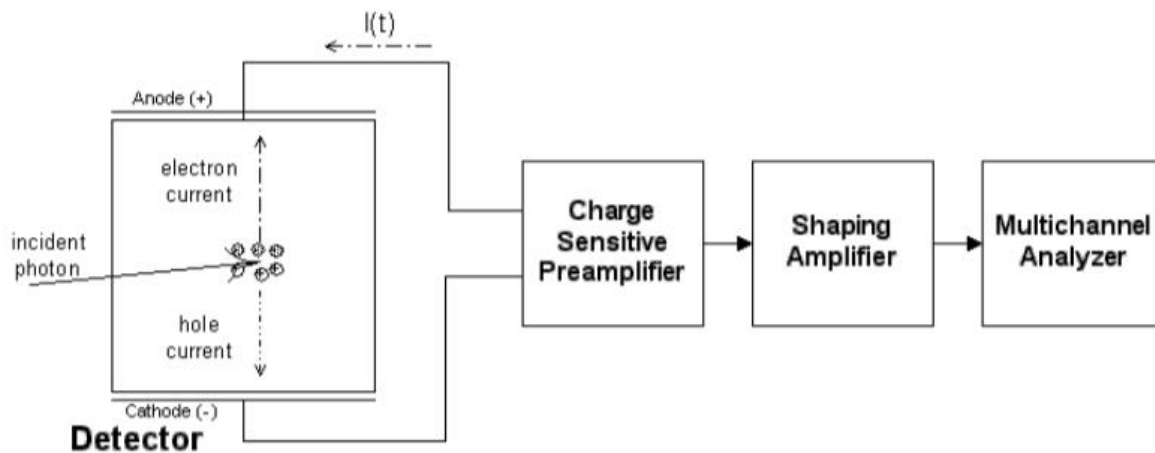

Figure 1: There is in the image a summarized description of a traditional spectrometry system. Image partially reproduced from the manufacturer manual (Amptek 2019).

In a general way, as shown in figure 1, the incident photon in the detection system will interact with the detector, that in this case is a semiconductor material, producing electron-hole pairs in the medium. These charges produced in the sensitive volume will be collected in the electrodes by the action of a voltage applied in the region and will go to the preamplifier, whose function is to make the electrical current become a voltage signal. After finished this stage, the signal will be treated and amplified in the amplifier to obtain an electric pulse and be separated by amplitude in the MCA (Multichannel Analyzer) (Gilmore 2008).

In that sense, the next item detail each block of the signal trajectory, focusing on the technical detail of the XR-100T CdTe, which involves the detector and the preamplifier and a PX5, whose functionality is attached to the amplifier and the MCA, from Amptek manufacturer (Amptek 2019).

It is important to highlight that the following discussion does not belong, in a direct manner, to scintillators and ion chambers. The problems of instrumentation in discussion are restricted to spectrometers of semiconductor material (Gilmore 2008).

1.2.1 Detector

The used detector is a Schottky CdTe diode. The choice for CdTe resides in the fact that it does not need a liquid nitrogen cooling, making it portable. However, this is not true for the hyper pure Ge that requires to be around 77 K to reduce the effects of leakage current. Besides this fact, it operates in a large energy range, with an efficiency of 50% in 100 keV and approximately 100% in the range of 10-60 keV. That is superior than the Si PIN detector that would be the portable low energy version, with 20% efficiency at 25 keV (Amptek 2019).

Although the CdTe possesses advantages when the topic is portability and energy range it molecule is diatomic and the confection of its crystalline structure is more susceptible to defects. Such as atomic interstices and crystalline structure defects in the diode that create traps for the charges produced in the medium and modify the conduction bandgap. For those reasons, the CdTe diode possesses lower charge mobility than Ge and Si. It is worth mentioning that, within years of use, the radiation produces damage to the detector, and that accounts for the creation of atomic interstices, degrading the charge collection (Gilmore 2008).

Table 1: Table containing data partially reproduced (Gilmore 2008).

Materials	Conduction Bandgap (eV)	Electrons Mobility (cm²/V.s)	Hole Mobility (cm²/V.s)
Ge¹	0,67	3,6x10 ⁴	4,2x10 ⁴
Si	1,106	1350	480
CdTe	1,47	1000	80

As can be seen in table 1, Ge possesses the lower value of the conduction bandgap. This physically means that electrons will migrate easier to the conduction band by thermic excitation, producing in that way a leakage current in the detector. For that reason, Ge needs cryogenic refrigeration with liquid Nitrogen at 77 K. On the other hand, the Si and CdTe detectors possess a large bandgap that reduces the effect of leakage current and vanish the need for cryogenic refrigeration. So in that way, it is a portable type of detector operating at room temperature with a small cooler inside it (Gilmore 2008; Amptek 2019).

Another relevant fact to highlight is the electron-hole mobility that impacts in spectral resolution because of defects in the crystalline structure. In that sense, the manufacture of Ge consists of high purity and homogeneous material. For that fact, is possible to observe an astonishing mobility value

¹The values in the table referring to conduction band gap were obtained at 77 K for the Ge and 300 K for the others. In that way, the data is representing approximately values of real operation temperatures.

when compared to other materials, not only to Si and CdTe. On the other hand, the worse mobility of CdTe in comparison to Si is due to its manufacturing processes. Monoatomic materials tend to have a higher homogeneity than diatomic. In that sense, the CdTe diode can produce some regions with an excess of Cd or Te degrading charge mobility (Gilmore 2008).

1.2.2 Preamplifier

After the charges have been generated in the detector, they will be collected in a feedback capacitor of 50 fF in the preamplifier. Although its prefix may suggest that one of its functions is to amplify the signal, it only indicates that it is a circuitry before the amplifier (Amptek 2019).

In the case of the used detector, there is a TRP system (Transistor Reset Preamplifier), rather than a traditional resistor of the order of $10^9 \Omega$. This prevents the capacitor of a premature saturation when the events are depositing charge in the sensitive volume. Another key factor to highlight is that the TRP is the ideal system for high count rates when compared to the resistive feedback, because of its late and smoother system lock up and also because it produces output signals that do not need pole-zero cancelation in the amplifier (Amptek 2019; Gilmore 2008).

In summary, the importance of this system is to collect an electric current signal and integrate it (1) in the feedback capacitor to produce an output voltage signal, represented as the element (b) in figure 2. This is of high importance because when analyzing voltage it is possible to run a pile-up rejection mechanism in parallel with the shaping procedure in the signal that will go to the MCA, without modifying the information of the peak voltage. However, it would occur if the systems were connected in series or analyzed in terms of electric current (Amptek 2019).

$$(1) \quad V(t) = \frac{1}{C_F} \int_{t_0}^{t_1} I(t) dt$$

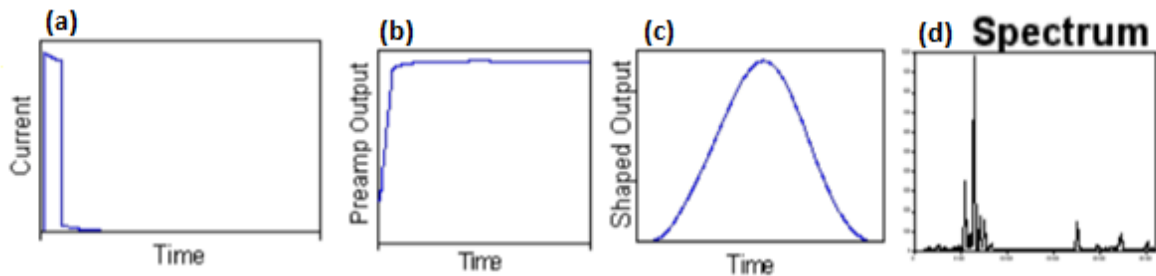

Figure 2: In the image, there is a description of the signal behavior in the spectrometry system. Letter (a) there is the input signal in the preamplifier, (b) the input signal of the amplifier, (c) the input signal of the MCA, and (d) the output signal from MCA that is the spectrum. Image partially reproduced from the manufacturer manual (Amptek 2019).

1.2.3 Amplifier

The traditional amplifiers in the spectrometry environment treat the pulses from the preamplifier analogically with a specific circuitry and have the mechanism of signal amplification, pole-zero cancelation, baseline restoration, and pile-up rejection. After that, the signal is digitalized by an ADC (Analog-to-Digital Converter) and separated in energy bins inside the MCA, creating a histogram. However, the PX5 works in a different way. The ADC is allocated in the preamplifier output implying that instead of treating the signal analogically, the amplifier will treat it digitally using a digital filter to do the shaping procedures in a FPGA (Field Programmable Gate Array). It keeps the same resources that an analog amplifier, but with less electric noise (Amptek 2019; Gilmore 2008).

In that way, the main role of the amplifier could be resumed as the input voltage shaping looking to transform it in a voltage pulse. Besides that main function, it is also capable of running a pile-up rejection technique in parallel with the signal that will be read and separated in the MCA.

1.2.4 MCA

The multichannel analyzer is the spectrometry element that dialog whit the analog signal which came from the amplifier, in traditional systems. Then, it separates the pulses according to their heights in different channels transforming the analog voltage signal in a digital signal of count in a specific channel. In the PX5 case, the signal that reaches the MCA is already a digitalized pulse and its separation in channels is also made by a FPGA (Amptek 2019; Gilmore 2008).

In summary, the main role of a MCA is to acquire information from the amplifier to trigger the arriving signals rejecting out of range or piled up pulses, measure pulse voltage height, and register it in memory building a spectrum.

2. MATERIALS AND METHODS

It was obtained seven spectra. One refers to an Am-241 source and the other six are narrow beam geometry qualities N20, N25, N60, N80, and N100. All the spectra were acquired using the XR-100T CdTe spectrometer coupled to a PX5 and was done a calibration and data acquiring by the software DPPMCA. The graphic elaboration was done in the analysis software GNU Octave.

In that sense, the experimental procedure begins with the acquisition of an Am-241 sealed source spectrum, positioned immediately after the detector Be window, for 4 min. This stage is always necessary to calibrate the scale in channels with a scale in energy. After that, the detector was irradiated by the GE X-ray tube SEIFERT X-ray Tubehousing 160 M2/0.4-1.5 with Be intrinsic filtration of 1 mm. In this case, because of high particle fluence, when in comparison with Am-241 source, it is necessary to use a tungsten collimator of 1 mm thickness with a pinhole of 400 μm to avoid pile-up distortions.

And lastly, for the mean energy calculation, it was used equation (3) which is a discrete interpretation of equation (2). This last one is destined for the spectrum continuous function, described in ISO 4037-1 (ISO 1996). In that way, the experimental data were calculated more adequately, because the spectrometer gives discrete data, and also avoid adjusting a function with regions where ϕ_E do not exist.

$$(2) \quad \bar{E} = \frac{\int_0^{E_{max}} \phi_E E dE}{\int_0^{E_{max}} \phi_E dE} ; \phi_E = \frac{d\phi(E)}{dE}$$

Where $\phi(E)$ is the photon fluence. However, according to integration and derivation fundamentals theorems, it is possible to observe spectrum mean energy by equation (3), without losing generality.

$$(3) \quad \bar{E} = \frac{\sum_{i=0}^{E_{max}} c_i E_i}{\sum_{j=0}^{E_{max}} c_j}$$

Where c represents the count associated with each energy value. Both equations are equivalent mean energy approaches, as can be seen in integration and derivation properties (Stewart 2009).

3. RESULTS AND DISCUSSION

The obtained results will be discussed in two ways. First of all, it will be done a qualitative highlight of some relevant spectrometry aspects that Am-241 source provides. After that, will be quantitatively discussed the obtained X rays spectra, evaluating their mean energy.

3.1 Quantitative Discussion

It is expected that the reader, since the beginning, is questioning why analyzing the source spectrum is important when the work is interested in X-ray spectra. The answer is due to the fact that the Am-241 spectrum brings a better lucidity about the physical process occurring in a low energy photon spectrometry. Not only that, but it is also a vital tool for X-ray spectrometry, been an excellent spectrum calibration source. This is due to the lack of true coincidence summing possibility of its γ rays, relatively big half-life, and its five easily distinguished peaks. It is worth mentioning that the large use of the Am-241 source for high energies is due to the amplifier and ADC's good linearity response that is typically 0,05% and 0,02%, respectively (Gilmore 2008). For that reason, the use of that source to spectra with high count rates and higher maximum energies than 60 keV does not represent a problem.

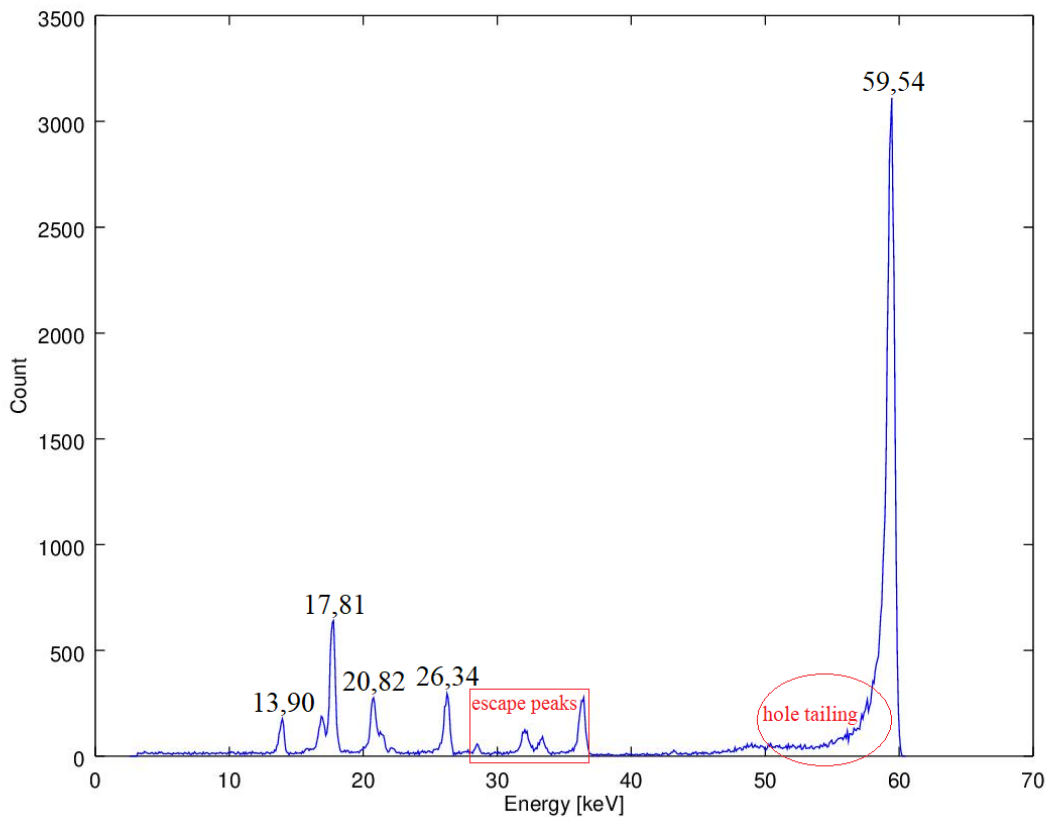

Figure 3: Sealed Am-241 source measured spectrum hole tailing.

As highlighted in figure 3, there are peaks due to the Am-241 decay, identified with nominal value, in keV obtained from IAEA (IAEA 2007). On the other hand, the regions demarked in red are not compatible with the source decay. So the red regions in the spectrum are issues from signal processing and detector material effects.

The peaks highlighted in the red rectangle do not possess a clear origin in the first analysis. However, those peaks are from the X-ray escape from the CdTe diode (Tomal, et al. 2015). In that sense, those X-rays emerging from the detector surface produce a partial energy deposition of the 59,54 keV generating four peaks with lower energy than de origin γ ray. Those peaks are called by scape peaks. In that sense, in figure 3 can be observed the peaks of 23,3 keV and 26,1 keV of k_{β} and k_{α} from Cd and 27,5 keV and 31,0 keV of k_{β} e k_{α} from Te (Redus, et al. 2009).

On the other hand, the red ellipse in the 59,54 keV peak highlights an asymmetry of hole trapping effect due to a poor charge collection. It is observable with the photon energy increase, making it go deeper inside the detector. These distancing results in higher time to collect the holes, which makes it easier to trap these charges because of lower mobility shown in table 1. For that reason and the fact that the signal is a composition of electrons and holes collection, it is possible to observe a partial collection of photon initial energy producing this tailing effect (Amptek 2019; Redus, et al 2009; Tomal, et al 2015).

Besides the source decay peaks and the red highlighted regions, it is possible to observe, in a shy way, a Compton plateau over the entire spectrum. It happens because the original signals from the

incident radiation are collected with higher efficiency if the interaction is due to the photoelectric effect. On the other hand, there is a partial charge deposition in the medium when the photon undergoes Compton scattering, leading to a loss of photons and electrons emerging from the detector. For that reason, there are counts in the entire spectrum, rather than only on the nominal energy of the X and γ radiation (Gilmore 2008).

3.2 Quantitative Discussion

As seen previously, the Am-241 source possesses some spectral adversities. Those distortions are not only remarkable to radionuclides spectra. They are also present in X-rays tube spectra in a veiled way. For that reason, a qualitative analysis is not capable to detect those distortions, making necessary the evaluation of system physical quantities to observe them.

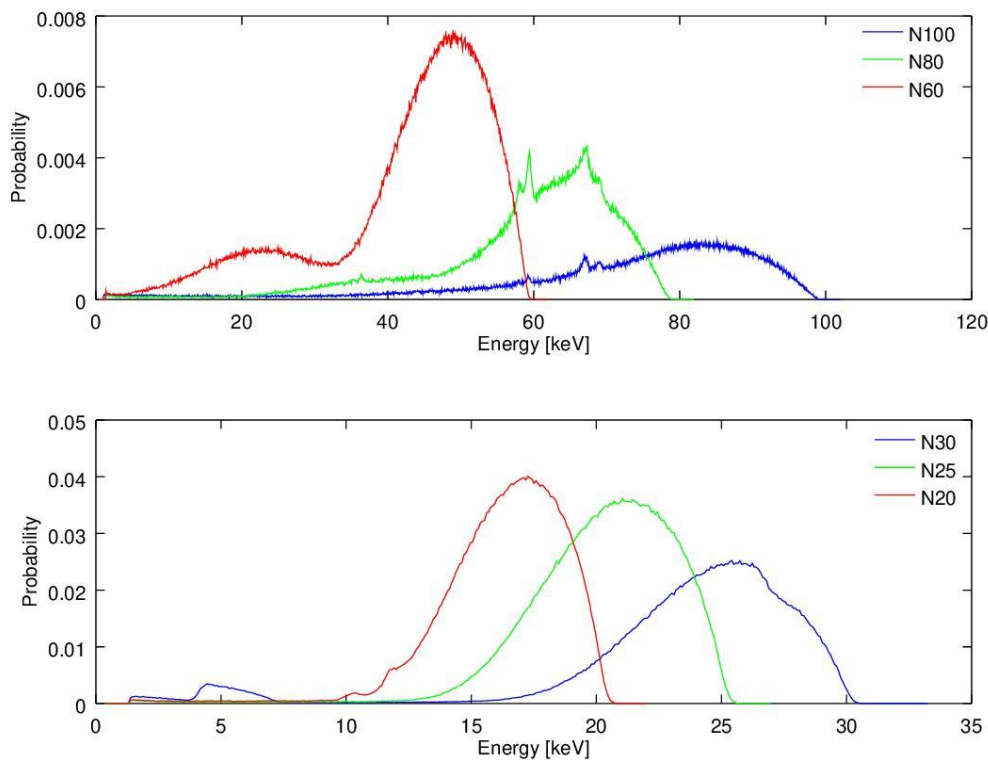

Figure 4: In the image, it can be observed the tube X-Ray spectra qualities N20, N25, N30, N60, N80, and N100.

As can be seen in table 2, there is the calculated mean energy for each one of the qualities in figure 4. It is worth mentioning that in figure 4 the counts were normalized, reflecting the meaning of probability. This normalization was done to make more attractive the visual disposal of the qualities.

Table 2: Experimental mean energy compared with the predicted in norm ISO 4037-1.

Voltage (kV)	20	25	30	60	80	100
Experimental (keV)	16,3	20,3	23,5	42,7	59,0	77,8
ISO 4037-1 (keV)	16	20	24	48	65	83
Error (%)	2	2	-2	-11	-9	-6

As pointed out in the Am-241 source discussion, the escape peaks, hole trapping, and partial energy deposition from the Compton effect also happens to those measured spectra. For that reason, in table 2, the 20 kV, 25 kV, and 30 kV qualities agree with the ISO 4037-1, even if is observed a 2% positive error (BIPM 2017). On the other hand, when increasing the energy of the beam, it is observed a dissonance with larger negative errors in comparison with the reference.

In that sense, it is reasonable to question why there are agreements and disagreements with the norm. Firstly, it must analyze the effect of escape peak, in the case of a continuous spectrum made by the tube is more accurate to call it by the escape of characteristic X rays. In order to be possible to produce it, is necessary photons with energies higher than 23 keV, Cd k_{α} energy, or superior to 27 keV, Te k_{α} energy. In other words, this escape effect does not produce great distortions until 30 kV, been important for higher energies photons of other qualities. However, its influence decreases exponentially with the increase in energy, because of the reduction of photoelectric cross-sections values (Tomal, et al. 2015).

Another negative effect that accounts for the disparities with the reference is the reduction of photoelectric cross-sections with the increase of the energy. In that sense, the qualities higher than 60 kV, inclusive, are more susceptible to partial energy deposition due to the escape of electrons and photons by Compton scattering in the sensitive volume (Amptek 2019).

Another issue, maybe not so clear, is the reduction of the count rate by the efficiency decrease with the increase of energy. This became more evident to energies higher than 60 keV because the efficiency starts it falls to values under 99% reaching 50% in 100 keV. This effect will underestimate high energy photon counts accounting for a beam softening (Amptek 2019).

Finally, the last error to be highlighted is the hole trapping that increases with an increase in the energy beam. This occurs because the beam goes deeper into the sensitive volume distancing from the electrode that collects the produced holes. The lower is the interaction energy, until 14 keV, they will be next to the cathode possessing a high-quality signal. However, the higher is the energy, about more than 59,5 keV, the interactions tend to be closer to the anode providing bigger trapping, because the holes will have to cross the detector what increases the signal degradation (Redus, et al. 2009).

4. CONCLUSION

In summary, the efficiency problems, partial energy deposition, and hole trapping highlighted in the work must be analyzed with caution, because they produce significant distortions to the physical quantities associated with the radiation beam. In that sense, the results indicate that measured beams with CdTe until 30 kV do not produce great distortions to its profile, because that energies there are not or are less susceptible to the presented problems. However, when increasing the beam voltage

values the mean energies are underestimated in comparison with the ISO 4037-1. This reveals a softened beam due to partial energy deposition, hole trapping, and efficiency loss.

A solution to these problems is to perform corrections in the measured spectra with the assistance of the Monte Carlo method simulation to deal with partial energy deposition. On the other hand, there are deterministic approaches to correct the charge trapping and efficiency loss.

ACKNOWLEDGEMENTS

I would like to thank the Instituto de Radioproteção e Dosimetria, Universidade do Estado do Rio de Janeiro and the Departamento de Ciências Radiológicas for the financial support to the research. It is of high relevance to also thank to the CNPq for the scholarship PIBIC of number 129940/2019-4 that helps in events participation. Finally, it is also relevant to thank to the entire research group partner to DSc. José Guilherme and in special to MSc. Leonardo Pacífico and to MSc. Eric Matos for the constructive discussions in the elaboration of the research.

REFERENCES

- [1]- Amptek “Application Note ANCZT-2 Rev. 3 Charge Trapping in XR-100T-CdTe and -CZT Detectors.” Amptek Inc. 2020. <https://www.amptek.com/-/media/ametekamptek/documents/resources/anczt2.pdf> (accessed on June 26 of 2020).
- [2]- “Application Note: Reset Preamplifier.” Amptek Inc. 2019. Application Note: Reset Preamplifier (accessed on June 26 of 2020).
- [3]- “CdTe Measurement of X-Ray Tube Spectra: Escape Events Application Note ANCDTE1 Rev A1.” Amptek Inc. 2019. <https://www.amptek.com/-/media/ametekamptek/documents/products/ancdte1.pdf> (accessed on June 26 of 2020).
- [4]- “Characterization of CdTe Detectors for Quantitative X-ray Spectroscopy.” Amptek. 2019. https://www.amptek.com/-/media/ametekamptek/documents/resources/cdtequant_paper.pdf (accessed on June 26 of 2020).
- [5]- “Glossary.” Amptek Inc. 2019. <https://www.amptek.com/-/media/ametekamptek/documents/products/glossary.pdf> (accessed on 26 June of 2020).
- [6]- “PX5 User Manual and Operating Instructions.” Amptek.
- [7]- “Si-PIN vs CdTe Comparison.” Amptek Inc. 2019. <https://www.amptek.com/internal-products/si-pin-vs-cdte-comparison> (accessed on April 13 of 2020).
- [8]- “What are DP4, PX4 and X123? How are they different?” Amptek Inc. 2019. https://www.amptek.com/-/media/ametekamptek/documents/products/digital_faq.pdf (accessed on June 26 of 2020).

- [9]-BIPM. *International Vocabulary of Metrology – Basic and General Concepts and Associated Terms*. 2017.
- [10]- Gilmore, Gordon. *Practical Gamma-ray Spectrometry*. John Wiley & Sons, Ltd, 2008.
- [11]- IAEA. *Update of X Ray and Gamma Ray Decay Data Standards for Detector Calibration and Others Applications, Volume 1*. 2007.
- [12]- ISO. “Radiological Protection - X and gamma reference radiation for calibrating dosimeters and doserate meters and for determining their response function as a function of photon energy - Part 1: Radiation characteristics and methods.” 1996.
- [13]- Redus, Robert H., John A. Pantazis, Thanos J. Pantazis, Alan C. Huber, e Brian J. Cross. “Characterization of CdTe Detectors for Quantitative X-ray Spectroscopy.” IEEE, 2009: 2524-2532.
- [14]- Stewart, James. *Cálculo, volume 1*. Cengage Learning, 2009.
- [15]- Tomal, A., J. C. Santos, P. R. Costa, A. H. Lopez Gonzales, e M. E. Poletti. “Monte Carlo simulation of the response functions of CdTe detectors to be applied in x-ray spectroscopy.” *Applied Radiation and Isotopes*, 2015.